

piA-AM3505

Features

- OMAP Singleboard-Computer
- Super-scalar ARMv7 Cortex™-A8
- up to 600MHz
- Top-hat rail housing
- Ethernet, µSD, USB, RS232/485, CAN
- DC 10 - 24V
- < 3 W Power Consumption
- Ångström Linux
- Kernel 2.6.37
- Open-Source SDK



Overview

The piA-AM3505 is a single board computer based on ARM®'s Cortex™ A8 architecture enclosed in industry standard top-hat rail housing. Its combination of above-average performance combined with high power efficiency makes the piA-AM3505 a good choice for mobile communication as well as stationary controller applications. Due to its small size it is the ideal solution, when there is not enough space for a full-sized PC system.

In addition to Ethernet, RS485 and USB, the piA-AM3505 allows data exchange via CAN and GSM / GPRS. Additional features such as Wi-Fi, RFID, Bluetooth, LCD displays, cameras, IO-Ports can be added via customer-specific expansion boards.

The sustainability of the system is underlined through the use of state of the art operating systems (embedded Linux, Windows CE and Android). In addition to interpreters for Python, Perl ea. included the base system, the piA-AM3505 comes with an open-source Linux based C/C++ cross compiler SDK for native application development.

Since the piA-AM3505 is based on the wide-spread Beagle-/Craneboard designs, there is a large and actively supporting open-source development community.

Details

Basics	
CPU	OMAP AM3505 Sitara™ ARMv7 microprocessor (MPU) 600 MHz Cortex™-A8 Core NEON™ FPU 1200 DMIPS
RAM	2 x 1Gb DDR2 SDRAM (256 Mbyte)
Flash	2Gb NAND Flash (256 Mbyte)

Interfaces	
Ethernet	10/100 Mbps Ethernet with RJ-45 connector
µSD	SD/MMC/SDIO
CAN	Isolated 5V CAN Transceiver
RS232/485	±25V RX / ±5V TX
Terminal/Debug	±25V RX / ±5V TX
HS USB 2.0	microUSB connector
GPIO	1 x TTL GPIO

Special Functions	
Sensors	3D-Acceleration Temperature
RTC	Real Time Clock with NTP synchronization Incl. Rechargeable Battery
Watchdog	1 x timer watchdog, 1 x power supervisor
GSM/UMTS (optional)	GC864-Quad-V2 GSM/GPRS UC864-E UMTS / HSDPA
Expansion Header (2x 40-pin) *	MMC/SDIO GPIOs UART SPI I2C
Debug	1 x JTAG, 1 x RS232

Other Features	
Board Size	96.2mm x 99mm
Power	USB 5V DC 10 - 24V 2A max
Typical Power Consumption	< 3W
Temperature Range	-10°C - 70°C
Enclosure	CH20M22, IP20, Top-hat rail housing, 1u

Software & Documentation
Ångström Linux with kernel 2.6.37
Open-Source SDK with board-specific libraries
Hardware Documentation
Software Documentation

*** Available expansion cards:**

- piA-Wireless (Wi-Fi, BT, RFID)
- piA-LCD (RGB-LCD)
- piA-ChargingControl
- piA-Motor
- piA-IO.Expander

*** Customized development of expansion cards**

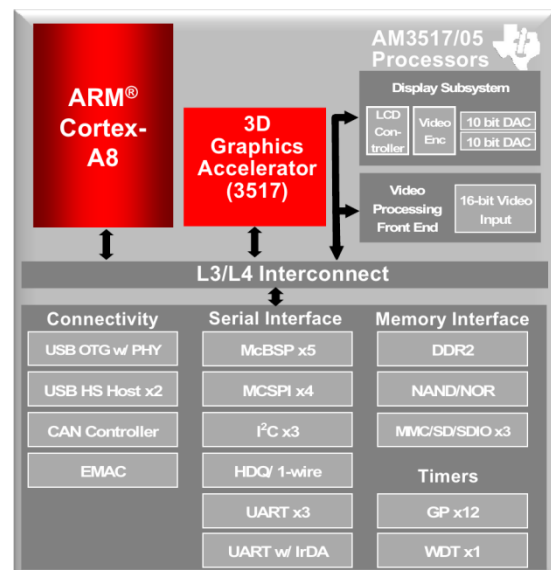

Figure 1: Functional Block Diagram for AM3517/05
© Texas Instruments